

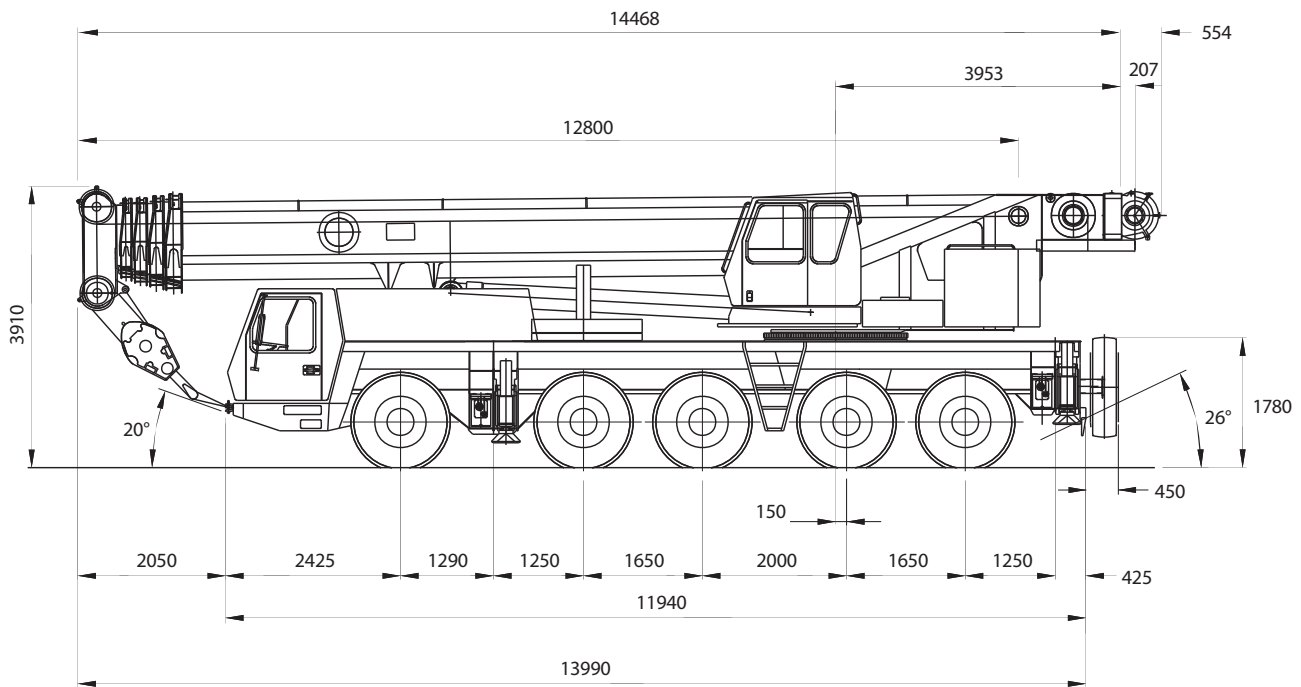

# 100 t AUTOKRAN MIT INTEGRIERTEM 550 KW AGGREGAT UND RÜTTLER MÜLLER MS 24 HFV

## GROVE GMK 5100



Straßengewicht: 60 t  
Einsatzgewicht mit Rüttler: 92 t

